

Part No. 38622
For 1.9 in. diameter roller

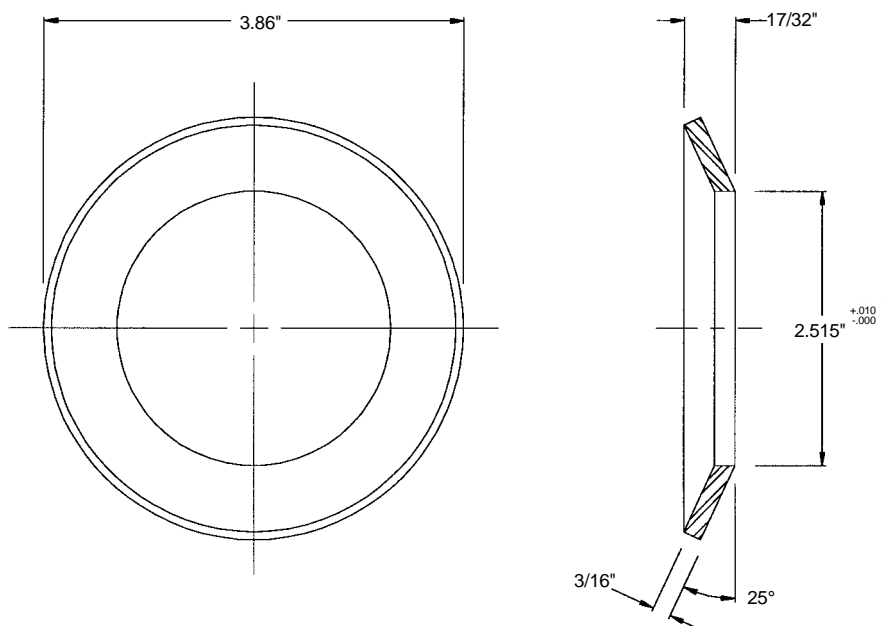

Part No. 37579
For 2 1/2 in. diameter roller