

## Roller 1.9 in. O.D. x 16 ga. - 7/16 in. Hex Axle for High Speed, Low Noise Applications

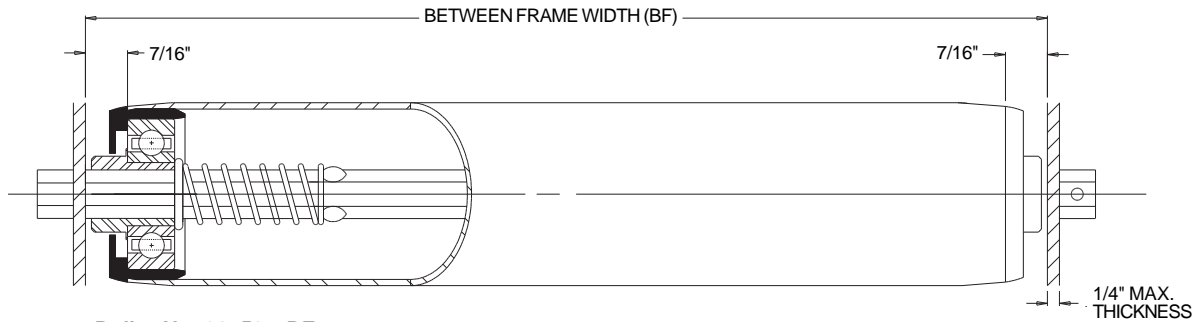

Roller No. 38756 - BF

Roller No. 38755 - BF

### Description:

**Tube:** 1.9 in. O.D. x 16 ga. (.065 in.)

**Axle:** 7/16 in. Hex

**Spring No.:** 11375

**Pin No.:** 101010

**Weight (lbs.):** 0.35 + 0.15 x BF

**Option:** Galvanized Tube, Grooved Roller

Roller No.	Bearing No.	Retained	BF
38756 - BF	111524 - Shield	Spring	7 - 39
38755 - BF	111524 - Shield	Pin	7 - 39

ROLLER CAPACITY CHART (LBS.)			
BF*	Bearing No. 111524	BF*	Bearing No. 111524
7	300	25	212
9	300	27	195
11	300	29	181
13	300	31	169
15	300	33	158
17	300	35	149
19	284	37	140
21	255	39	133
23	231		

\* Other Between Frame Widths available. See chart at left.

The double shielded bearing is shown for this roller.

Other seal/shield arrangements are available for the ABEC #1 bearing. Ask for details.

## Roller 1.9 in. O.D. x 16 ga. - 1/2 in. Round Axle

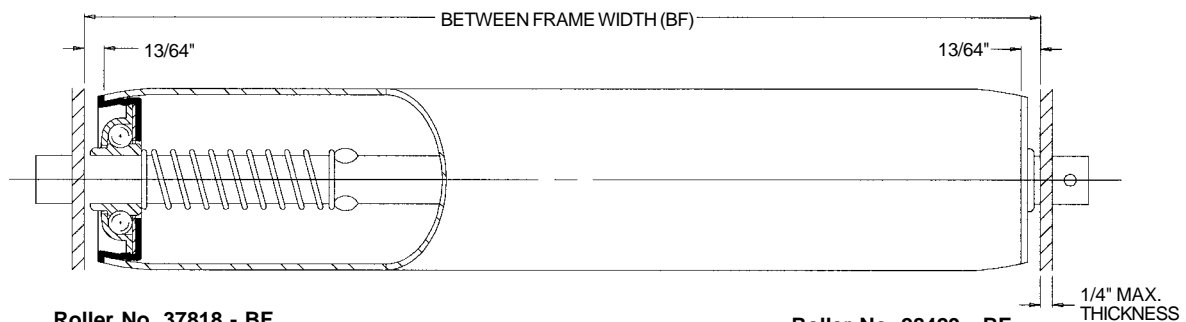

Roller No. 37818 - BF

Roller No. 28429 - BF

### Description:

**Tube:** 1.9 in. O.D. x 16 ga. (.065 in.)

**Axle:** 1/2 in. Round

**Spring No.:** 11375

**Pin No.:** 101010

**Weight (lbs.):** 0.43 + 0.17 x BF

**Option:** Galvanized Tube

Roller No.	Bearing No.	Retained	BF
28429 - BF	102255 - Plain	Pin	3 - 63
37818 - BF	102255 - Plain	Spring	7 - 63

ROLLER CAPACITY CHART (LBS.)			
BF*	Bearing No. 102255	BF*	Bearing No. 102255
7	260	37	260
10	260	40	260
13	260	43	260
16	260	46	260
19	260	49	260
22	260	52	250
25	260	55	236
28	260	58	223
31	260	61	201
34	260	63	189

\* Other Between Frame Widths available. See chart at left.