

Roller 1 3/8 in. O.D. x 16 ga. - 5/16 in. Hex Axle for High Speed, Low Noise Applications

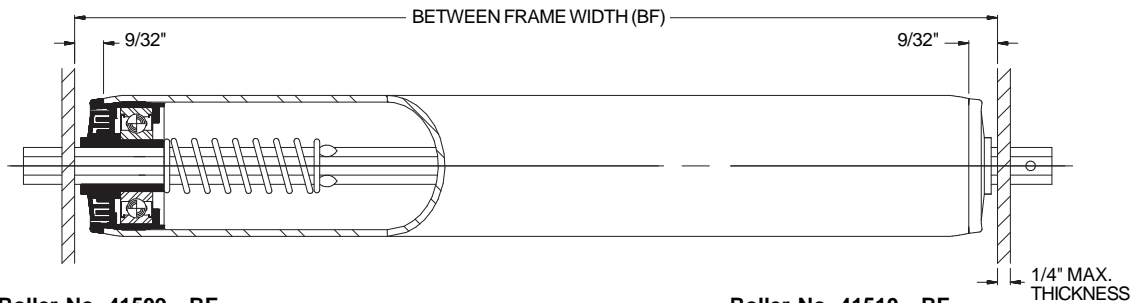

Roller No. 41509 - BF

Roller No. 41510 - BF

Description:

Tube: 1 3/8 in. O.D. x 16 ga. (.065 in.)

Axle: 5/16 in. Hex

Spring No.: 11372

Pin No.: 101136

Weight (lbs.): 0.06 + 0.10 x BF

Option: Galvanized Tube, Grooved Roller

ROLLER CAPACITY CHART (LBS.)			
BF*	Bearing No. 113499	BF*	Bearing No. 113499
7	100	25	61
9	100	27	56
11	100	29	52
13	100	31	48
15	100	33	45
17	91	35	43
19	81	37	40
21	73	39	38
23	66		

Roller No.	Bearing No.	Retained	BF
41509 - BF	113499 - Shield	Spring	7 - 39
41510 - BF	113499 - Shield	Pin	4 - 39

* Between Frame Widths available from 4 in. to 39 in.

The double labyrinth shielding housing is shown for this roller.

Other seal/shield arrangements are available for the ABEC #1 bearing. Ask for details.

Roller 1 3/8 in. O.D. x 16 ga. - 7/16 in. Hex Axle

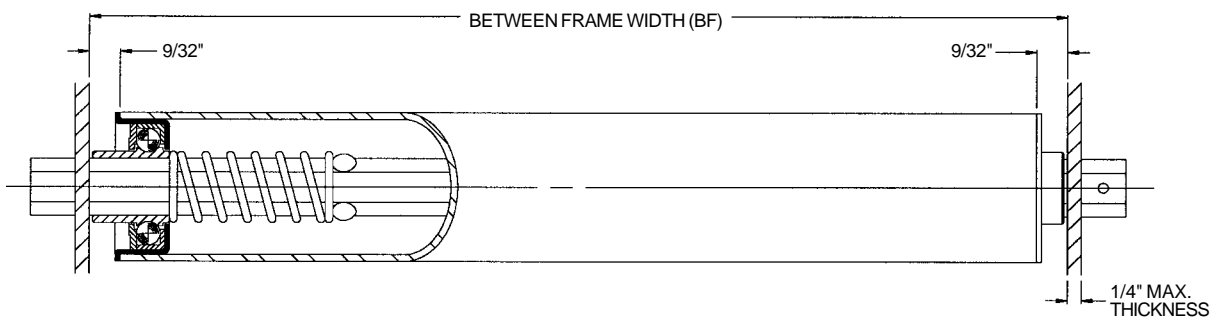

Roller No. 37974 - BF

Roller No. 37975 - BF

Description:

Tube: 1 3/8 in. O.D. x 16 ga. (.065 in.)

Axle: 7/16 in. Hex

Spring No.: 11375

Pin No.: 101010

Weight (lbs.): 0.17 + 0.12 x BF

ROLLER CAPACITY CHART (LBS.)			
BF*	Bearing No. 110528	BF*	Bearing No. 110528
7	170	25	170
9	170	27	170
11	170	29	170
13	170	31	170
15	170	33	170
17	170	35	170
19	170	37	170
21	170	39	170
23	170		

Roller No.	Bearing No.	Retained	BF
37974 - BF	110528 - Plain	Spring	7 - 39
37975 - BF	110528 - Plain	Pin	3 - 39

* Other Between Frame Widths available. See chart at left.